



STERYLIS LIGHT AIR+ 120 is a 2-in-1 device combining the function of air disinfection (UV-C technology) and room illumination with LED light sources. It is designed for both flush and surface mounting in coffered ceilings (corresponds to the size of a standard 120x60cm coffer).

Maximum recommended volume /
surface area of disinfected room for
LIGHT AIR +120 models

120 m³
40 m²



OPERATION:



UV-C disinfection

SPECIFICATION:

LIGHT AIR+ 120

Maximum recommended volume / surface area of room to be disinfected	120 m ³ 40 m ²
Average UV-C dose	59 J/m ²
Fan capacity- UV-C disinfection mode	180 m ³ /h
Noise level - UV-C disinfection mode	37 dB
Number of UV-C sources	4
Type of UV-C sources	25W T8 G13 254nm
Durability of UV-C sources	10800 h
Total electrical power of UV-C sources	100 W
Total radiant power of UV-C sources	32,8 W
Power supply	230 VAC / 50 Hz
Rated current	0,45 A
Rated electrical power	104 W
Fan type	axial
Fan electrical power	4 W
Built-in LED fixture	YES
LED fixture power	50 W
LED total flux	Diffusive - 5800 lm / Prismatic 5500 lm
Light colour	4000K / CRI80
Shade type	Diffusive / Prismatic (PMMA)

Dimensions (L x W x D)	1195x595x83 mm
Net weight	10 kg
Power cord	1,0 m
Housing type	metal, powder-coated
Additional functions	fault detection and signalling (fan, UV-C lamp) counting and indication of operating time of UV-C lamps timer / delayed shut-off
Optional installation method *	flush-mounted / surface-mounted
Certificates / approvals	CE, ISO

* - versions available after consultation with our sales department

PHOTOMETRY OF THE DEVICE WITH LED FIXTURE:

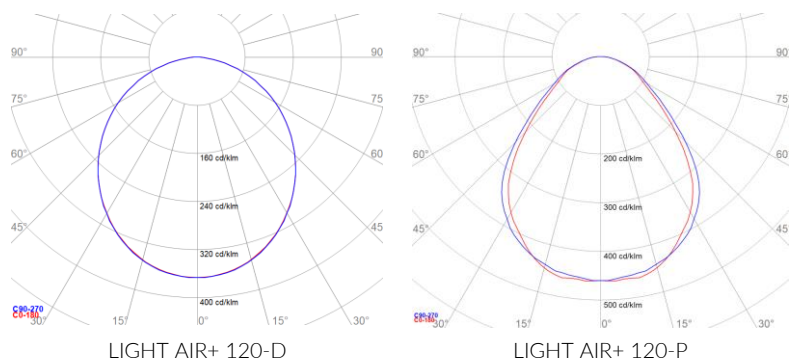

DIMENSIONS:

MODEL	DIMENSIONS			WEIGHT
	L [mm]	W [mm]	H [mm]	[kg]
LIGHT AIR+ 120	1195	595	83	10

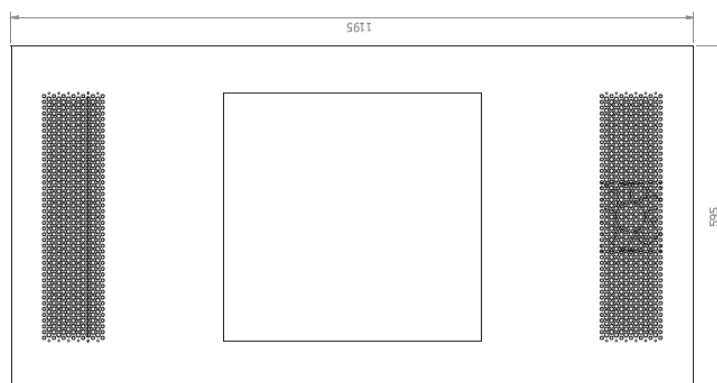
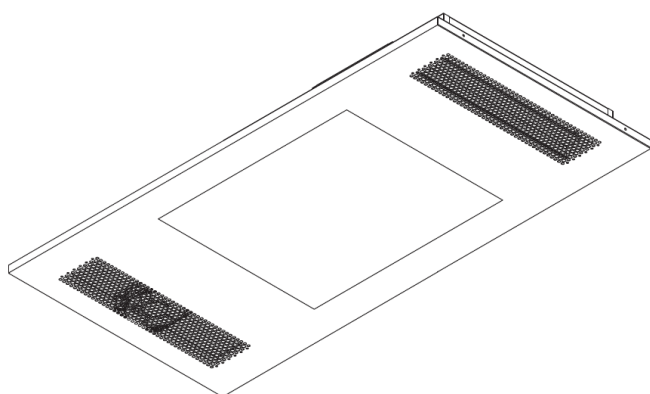
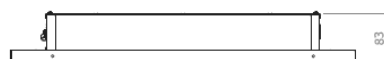

Due to continuous product development, we reserve the right to make design changes to the devices and update parameters
Revision date : 03.02.2021