

INSTALLATION AND OPERATION INSTRUCTIONS



IMPORTANT

Installation of the luminaire should be carried out by a duly authorised person.

SAFETY INSTRUCTIONS

Before proceeding to any work on the luminaire, always switch off the supply voltage first!

INTENDED USE:

S-LINE 2.0 luminaires are designed for surface mounting and pendant mounting in public buildings, warehouses and production halls.

LUMINAIRE INSTALLATION PROCEDURE:

1. Switch off the supply voltage.
2. Surface mounting: unscrew mounting brackets from the luminaire, fix to the surface using \varnothing 4 mm rawlplugs or screws at least 60 mm long (not included), depending on the type of surface (Fig. 1).
3. Screw the luminaire to the mounted brackets (screwdriver - PZ2).
4. Alternatively, the luminaire can be pendant-mounted, using wire slings (Fig. 2); mount a \varnothing 4 mm eyebolt in the holes provided for this purpose (using nuts), fix the slings to the ceiling, level the luminaire by adjusting the length of the wire slings.
5. Make sure that the mechanical assembly is correct.
6. Connect the power cables, pay special attention to the colours of the conductors when connecting them.
7. Secure the power cord in the power cord strain relief.
8. Switch on the supply voltage.

WALL MOUNTING DIAGRAM:

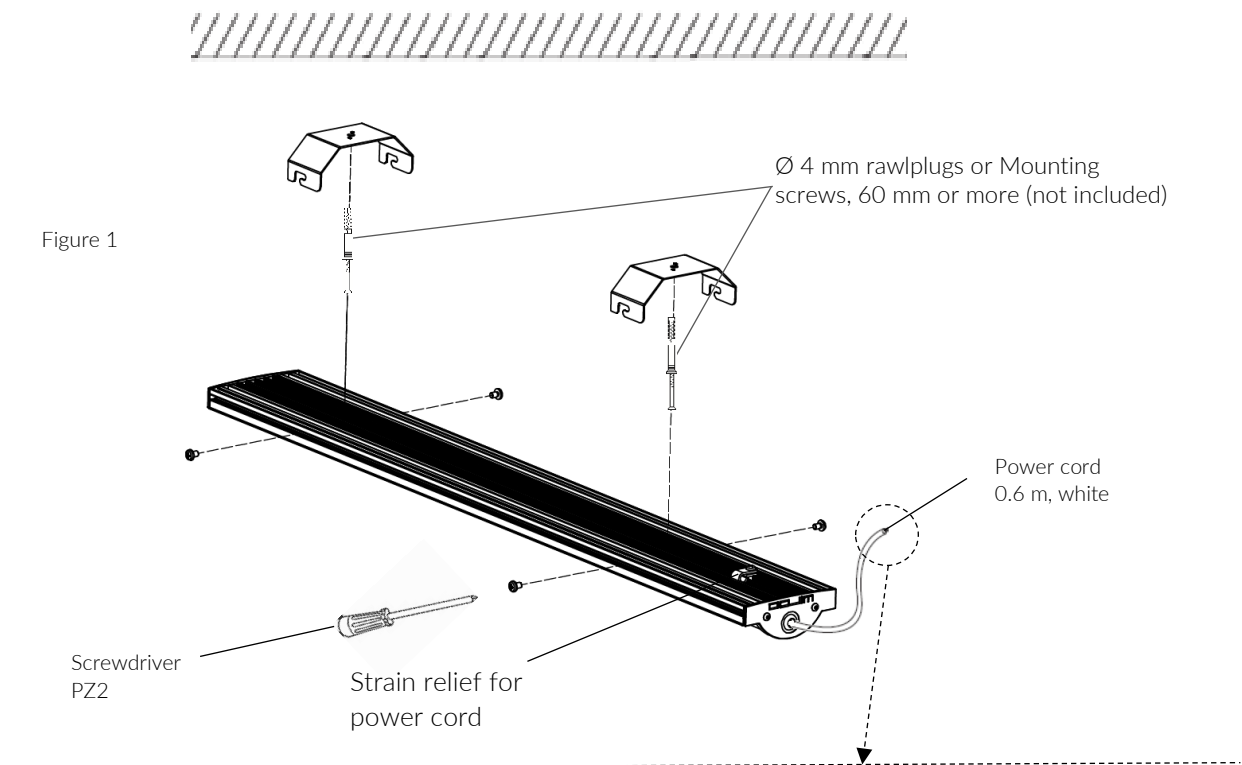

IP66 LUMINAIRE, IP20

DALI:

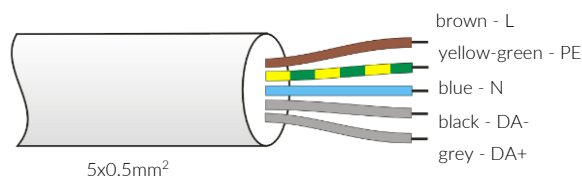

INSTALLATION DIAGRAM FOR WIRE SLINGS:

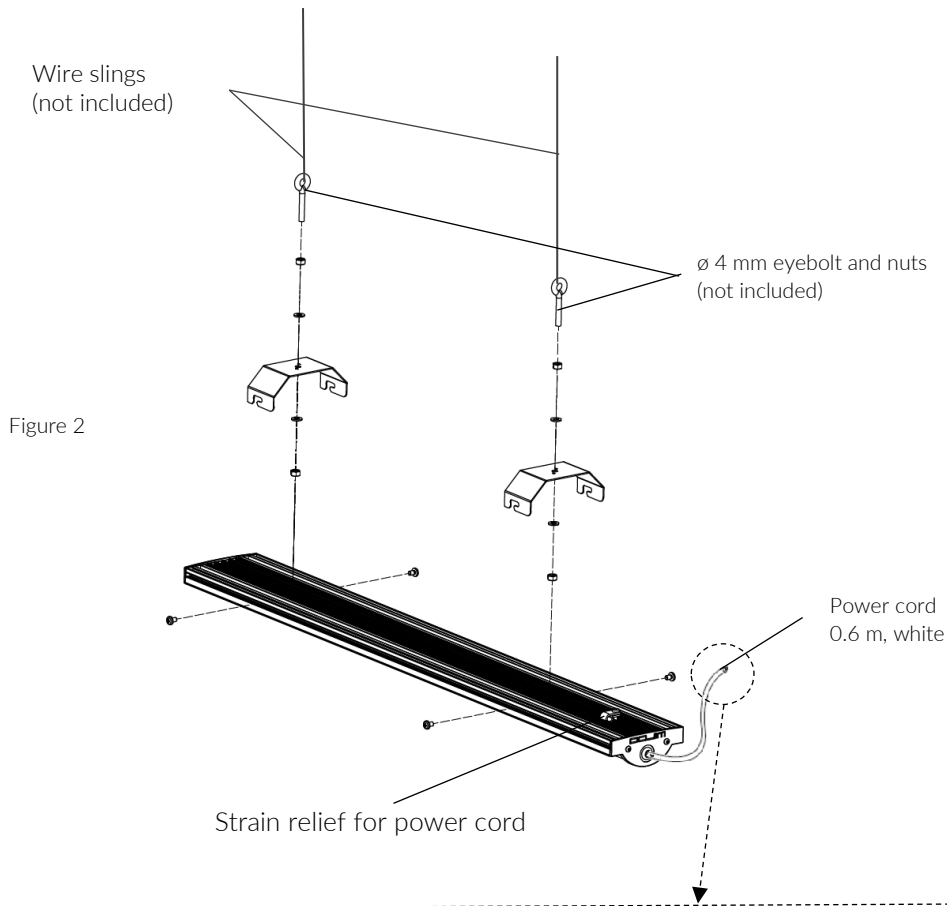

IP66 LUMINAIRE, IP20

DALI:

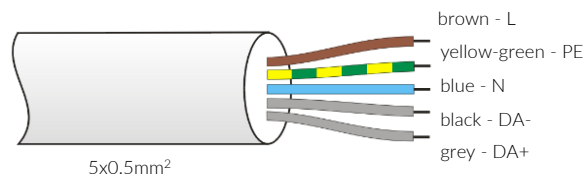

IP68 CONNECTOR (AVAILABLE ON REQUEST):

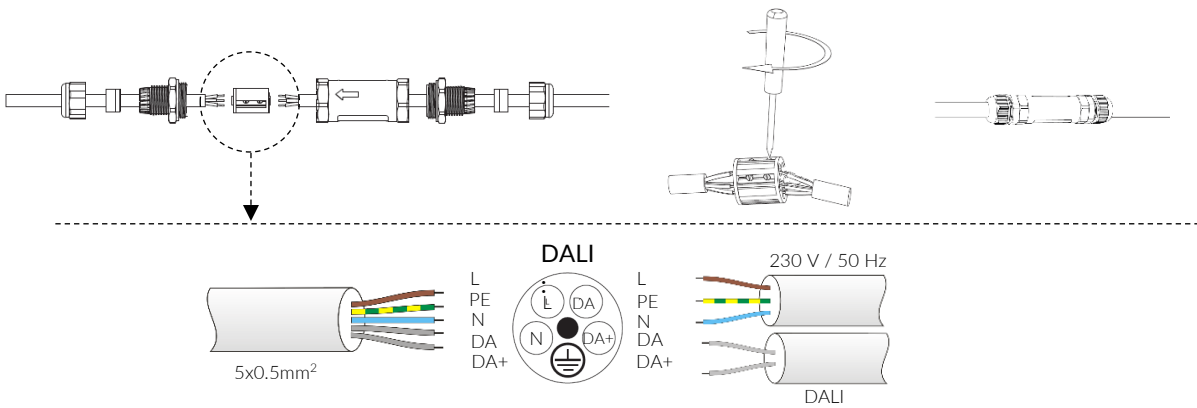

RECOMMENDATIONS REGARDING ROUTINE INSPECTION OF INSTALLED LUMINAIRES:

1. A visual inspection of luminaires should be carried out at least once every 12 months. The inspection involves checking if the luminaire illuminates correctly, the lampshade is undamaged or dirty, the luminaire is not mechanically damaged.
2. It is recommended that once every 24 months a periodic cleaning of the luminaires is carried out as per the recommendations. If the luminaire is used in harsh, dusty environments (such as cement works, metal works) it is recommended to clean it every 12 months or more often.

MAINTENANCE:

To ensure optimum luminous flux, carry out routine maintenance of the protective lampshade. Use cleaning agents for this purpose. Do not clean with pressurised water. Do not use caustic agents or solvents. Use a soft cloth to wipe the luminaire dry.

PRODUCT GUARANTEE:

1. The following product of MILOO-ELECTRONICS Sp. z o. o. was designed and manufactured as per the applicable standards. To ensure proper functioning and user safety, the product is subject to quality control procedures during the production process. MILOO-ELECTRONICS Sp. z o. o. grants a guarantee of proper quality and functioning of the luminaire.
2. The guarantee does not include liability for consequential damage caused to third party property.
3. The guarantee service involves repair or replacement of defective parts at manufacturer's discretion.
4. The guarantee will not cover damage to parts subject to wear and tear, damage and malfunctions caused by improper operation or maintenance.
5. During the guarantee period, the manufacturer will correct any deficiencies caused by defects in material or workmanship.
6. The guarantee is valid only if the luminaire (complete rather than disassembled into parts), a brief description of the defect, receipt, bill of sale (with the date of purchase and stamp of the store) or a copy of the purchase invoice is sent or delivered to MILOO-ELECTRONICS Sp. z o. o. location.

For general guarantee terms and conditions visit:

<https://www.emiloo.pl/en/files>

REPAIR SERVICE:

In case of defects subject to guarantee, please send or deliver the product to the address of our company. Any repairs of defects outside the scope of product guarantee as well as post-guarantee repairs are carried out by our in-house service team. Please send or deliver the luminaire to the manufacturer's address for visual inspection and cost estimate. The light source is not intended for replacement by the user. If the light source is damaged, contact the manufacturer.



Given the constant product development we reserve the right to introduce design changes in luminaires and update luminaire parameters.

Revision date: 15.10.2021