

# INSTALLATION AND OPERATION INSTRUCTIONS



## IMPORTANT

Installation of the luminaire should be carried out by a duly authorised person.

## SAFETY INSTRUCTIONS

Before proceeding to any work on the luminaire, always switch off the supply voltage first!

## INTENDED USE:

ASSEMBLY PROCEDURE OF BASSO SUPER SLIM / MEZZO LUMINAIRES on a surface using the BASSO SUPER SLIM 600x600 / MEZZO surface mounting kit (0818180000-0001-FF98):

## INSTALLATION METHOD:

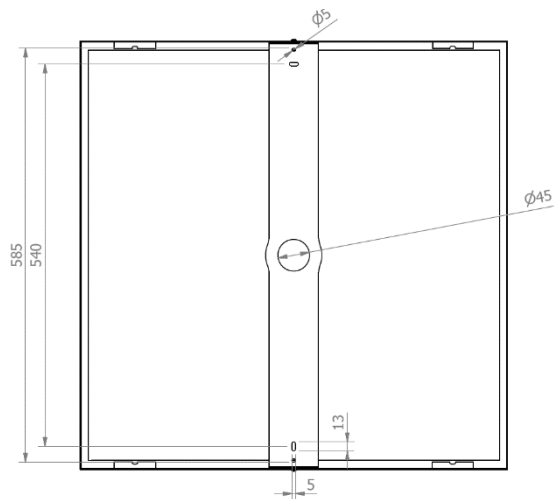
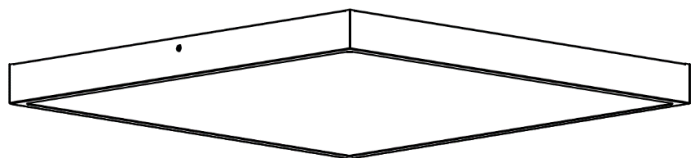

## LUMINAIRE INSTALLATION PROCEDURE:

1

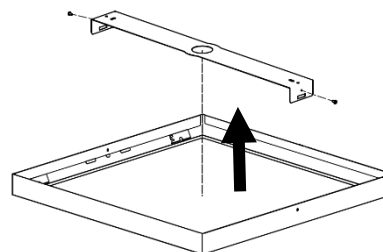

2

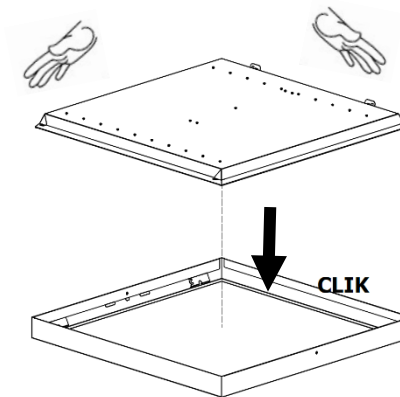

3

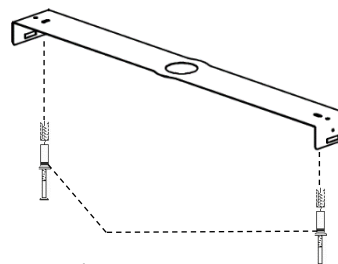

Wall plugs Ø 4 mm  
Not included

4

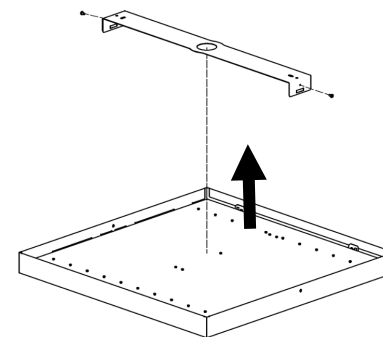

PZ2

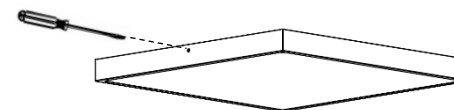

## CONNECTION DIAGRAMS:

When installing, pay attention to the factory markings on the luminaire and wire colours

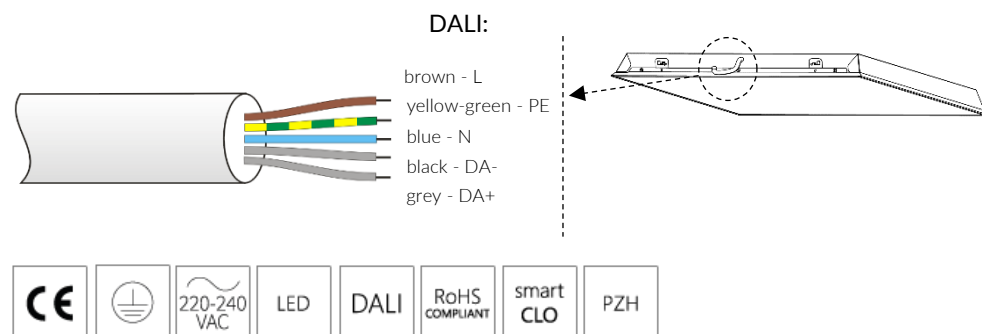

## MAINTENANCE:

To ensure optimum luminous flux, carry out routine maintenance of the protective lampshade. Use cleaning agents for this purpose. Do not clean with pressurised water. Do not use caustic agents or solvents. Use a soft cloth to wipe the luminaire dry.

## PRODUCT GUARANTEE:

1. The following product of MILOO-ELECTRONICS Sp. z o. o. was designed and manufactured as per the applicable standards. To ensure proper functioning and user safety, the product is subject to quality control procedures during the production process. MILOO-ELECTRONICS Sp. z o. o. grants a guarantee of proper quality and functioning of the luminaire.
2. The guarantee does not include liability for consequential damage caused to third party property.
3. The guarantee service involves repair or replacement of defective parts at manufacturer's discretion.
4. The guarantee will not cover damage to parts subject to wear and tear, damage and malfunctions caused by improper operation or maintenance.
5. During the guarantee period, the manufacturer will correct any deficiencies caused by defects in material or workmanship.
6. The guarantee is valid only if the luminaire (complete rather than disassembled into parts), a brief description of the defect, receipt, bill of sale (with the date of purchase and stamp of the store) or a copy of the purchase invoice is sent or delivered to MILOO-ELECTRONICS Sp. z o. o. location.

For general guarantee terms and conditions visit:

<https://www.emiloo.pl/en/files>

## REPAIR SERVICE:

In case of defects subject to guarantee, please send or deliver the product to the address of our company. Any repairs of defects outside the scope of product guarantee as well as post-guarantee repairs are carried out by our in-house service team. Please send or deliver the luminaire to the manufacturer's address for visual inspection and cost estimate.

The light source used in this luminaire should only be replaced by the manufacturer or its service representative, or a similarly qualified person.

Given the constant product development we reserve the right to introduce design changes in luminaires and update luminaire parameters.



Revision date: 15.10.2021