



## PL

Oprawa LED SWAY jest zewnętrzną oprawą oświetleniową montowaną na uchwycie. Może być mocowana do elewacji lub do podłoża. Istnieje możliwość wykonania na zamówienie modelu z klinem ziemnym. SWAY znajduje zastosowanie przy oświetlaniu elewacji i obiektów zewnętrznych. Występuje w kilku wariantach kąta rozsyłu światła. Oprawa współpracuje z systemem sterowania DALI.

## EN

The SWAY LED fixture is an external lighting mounted on a handle. It can be mounted on the building facade or on the ground surface. It is possible to order a model with a ground mounting stake. The SWAY fixtures are used for the illumination of building facades and external objects. Several variants of light distribution angle are available. The luminaire works with the DALI control system.

## DE

Die LED-Leuchte SWAY ist eine Außenleuchte, die an einer Halterung montiert wird. Sie kann an der Fassade oder am Boden montiert werden. Eine Variante mit Säule auf Anfrage möglich. SWAY findet die Anwendung zur Beleuchtung von Fassaden und Außenobjekten. Mit Abstrahlwinkel in mehreren Varianten. Die Leuchte arbeitet mit der DALI-Steuerung.

### OPCJE DO WYBORU / OPTIONS / OPTIONSWAHL MÖGLICH:



SP



3000 K 4000 K  
inna/different/andere\*\*



20° 30°  
40° 50°



biały/white/weiß  
inny/different/andere\*\*

SP - szyba z plamką / glass with a spot / Glas mit Fleck

\*\*Opcje dostępne na zamówienie po konsultacji z działem handlowym. / Options available on request, following consultation with the sales department. / Andere Optionen auf Bestellung nach der Beratung mit der Handelsabteilung erhältlich.

## PL

### PARAMETRY TECHNICZNE

Sposób montażu: natynkowy  
Obudowa: aluminium  
LED: 3 elipsa MacAdama (SDCM 3)  
Napięcie zasilania: 220-240 V / 50 Hz  
Współczynnik mocy (PF): 0,99  
Poziom zakłóceń harmonicznych THD < 5%  
Klasa ochronności: I  
Wskaźnik oddawania barw CRI(Ra): 85 /90\*\*  
Stopień ochrony: IK07  
Stopień szczelności: IP65  
Stopień szczelności przyłącza: IP20 /IP68  
Temperatura otoczenia: od -25°C do +35°C  
Wilgotność otoczenia: 20-80%  
Trwałość (L70B10): 100 000 h

**ZASTOSOWANIE:** obiekty użyteczności publicznej, korytarze, parkingi i przejścia podziemne, magazyny, hale przemysłowe, elewacje

## EN

### TECHNICAL PARAMETERS

Mounting: surface mounting  
Body: aluminium  
LED: MacAdam 3 ellipse (SDCM 3)  
Power Supply: 220-240 V / 50 Hz  
Power factor (PF): 0,99  
Harmonic distortion THD < 5%  
Protection class: I  
Color rendering index Ra: 85 /90\*\*  
Protection marking: IK07  
Protection marking: IP65  
Protection marking of connection: IP20 /IP68  
Ambient temperature: from -25°C to +35°C  
Ambient humidity: 20-80%  
Lifetime (L70B10): 100 000 h

**APPLICATION:** public utility buildings, corridors, car parks and underpasses, warehouses, industrial halls, elevations

## DE

### TECHNISCHE DATEN

Montageart: zur Aufputz-Montage  
Gehäuse: Aluminium  
LED: MacAdam 3-Ellipse (SDCM 3)  
Speisespannung: 220-240 V / 50 Hz  
Leistungsfaktor (PF): 0,99  
Harmonische Verzerrung THD < 5%  
Schutzklasse: I  
Farbwiedergabe Faktor Ra: 85 /90\*\*  
Schutzklasse: IK07  
Schutzklasse: IP65  
Schutzklasse Anschluss: IP20 /IP68  
Umgebungstemperatur: von -25°C bis +35°C  
Umgebungsluftfeuchtigkeit: 20-80%  
Lebensdauer (L70B10): 100 000 h

**EINSATZBEREICH:** öffentliche Gebäude, Korridore, Parkplätze und Unterführungen, Lagerräume, Industriehallen, Fassaden

Deklarowana trwałość dotyczy opraw pracujących w temperaturze otoczenia +25°C przy zapewnionych optymalnych warunkach wentylacji. / The declared lifetime applies to fixtures operating at an ambient temperature of +25°C with ensured optimal ventilation conditions. / Die erklärte Lebensdauer bezieht sich auf Leuchten, die bei einer Raumtemperatur von +25°C und optimalen Lüftungsbedingungen arbeiten.

\* Spełnienie warunku UGR<19 w sensie normy PN-EN 12464-1:2012 jest wymagane dla konkretnego projektu oświetleniowego i zależy od aktualnych warunków oświetleniowych / Compliance with UGR <19 in the sense of PN-EN 12464-1: 2012 is required for a specific lighting project and depends on current lighting conditions / Die Einhaltung von UGR <19 im Sinne von PN-EN 12464-1: 2012 ist für ein bestimmtes Beleuchtungsprojekt erforderlich und hängt von den aktuellen Lichtverhältnissen ab

PRODUKTY / PRODUCTS / PRODUKTE:

CODE

P

Tc



DALI



EAN	CODE	[W]	[K]	[°]	[lm]	[lm/W]	
<b>Typ: DALI, 4000K, IP65 / Type: DALI, 4000K, IP65 / Art: DALI, 4000K, IP65</b>							
5904441701142	047515D840-SP01-0803	20	4000	SP 20	2100	105	DALI
5904441701159	047515D840-SP01-0903	20	4000	SP 30	2350	118	DALI
5904441701166	047515D840-SP01-1003	20	4000	SP 40	2350	118	DALI
5904441701173	047515D840-SP01-1103	20	4000	SP 50	2350	118	DALI
5904441701180	047515D840-SP01-0806	30	4000	SP 20	2900	97	DALI
5904441701197	047515D840-SP01-0906	30	4000	SP 30	3200	107	DALI
5904441701203	047515D840-SP01-1006	30	4000	SP 40	3200	107	DALI
5904441701210	047515D840-SP01-1106	30	4000	SP 50	3200	107	DALI
5904441701227	047515D840-SP01-0809	40	4000	SP 20	3500	88	DALI
5904441701234	047515D840-SP01-0909	40	4000	SP 30	3900	98	DALI
5904441701241	047515D840-SP01-1009	40	4000	SP 40	3900	98	DALI
5904441701258	047515D840-SP01-1109	40	4000	SP 50	3900	98	DALI
<b>Typ: DALI, 3000K, IP65 / Type: DALI, 3000K, IP65 / Art: DALI, 3000K, IP65</b>							
5904441701265	047515D830-SP01-0803	20	3000	SP 20	2000	100	DALI
5904441701272	047515D830-SP01-0903	20	3000	SP 30	2200	110	DALI
5904441701289	047515D830-SP01-1003	20	3000	SP 40	2200	110	DALI
5904441701296	047515D830-SP01-1103	20	3000	SP 50	2200	110	DALI
5904441701302	047515D830-SP01-0806	30	3000	SP 20	2750	92	DALI
5904441701319	047515D830-SP01-0906	30	3000	SP 30	3000	100	DALI
5904441701326	047515D830-SP01-1006	30	3000	SP 40	3000	100	DALI
5904441701333	047515D830-SP01-1106	30	3000	SP 50	3000	100	DALI
5904441701340	047515D830-SP01-0809	40	3000	SP 20	3300	83	DALI
5904441701357	047515D830-SP01-0909	40	3000	SP 30	3700	93	DALI
5904441701364	047515D830-SP01-1009	40	3000	SP 40	3700	93	DALI
5904441701371	047515D830-SP01-1109	40	3000	SP 50	3700	93	DALI

Całkowity strumień świetlny oprawy zmierzony za kloszem przy temp. otoczenia +25°C. Tolerancja strumienia świetlnego +/- 10%. Pomiary fotometryczne zostały wykonane zgodnie z wymaganiami normy PN-EN13032. / The total luminous flux of the luminaire measured diffuser +25°C. Luminous flux tolerance +/- 10%. Photometric measurement were examined in accordance with the PN-EN13032 system. / Gesamtlichtstrom der Leuchte, gemessen hinter der Abdeckung +25°C. Lichtstrom-Toleranz +/- 10%. Photometrische Messungen wurden nach PN-EN13032 Norm geprüft.

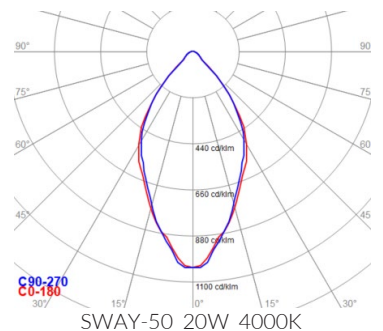
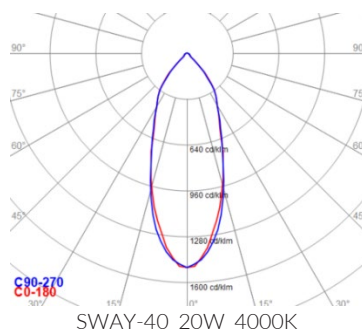
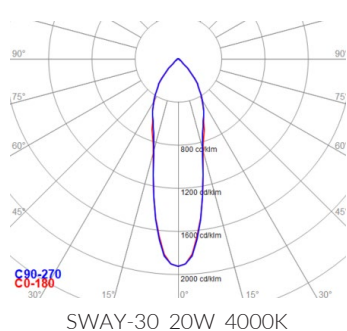
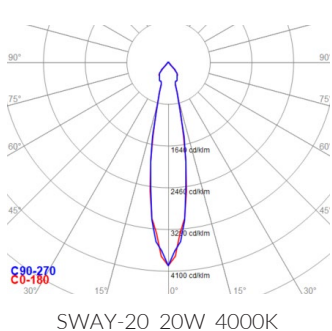
FOTOMETRIA / PHOTOMETRY / PHOTOMETRIE:



WYMIARY / DIMENSIONS / MASSE:



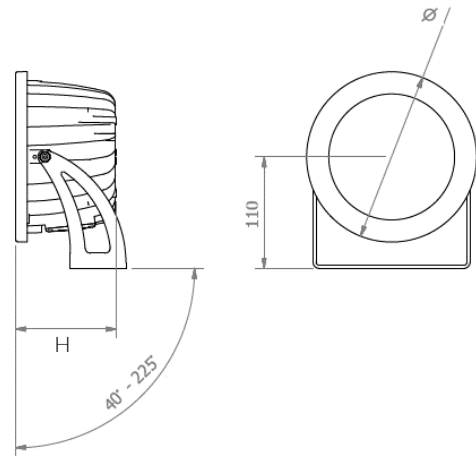



















NAME			
	∅ [mm]	H [mm]	[kg]
SWAY	168	100	1,4



W związku z ciągłym rozwojem produktów zastrzegamy sobie prawo do wprowadzania zmian konstrukcyjnych w oprawach oraz aktualizowania parametrów.  
 Due to continuous product development, we reserve the right to introduce structural changes in the fixtures and to update their parameters.  
 Aufgrund der ständigen Produktentwicklung behalten wir uns das Recht vor, technische Änderungen und Aktualisierung von Parametern an Leuchten vorzunehmen.

Data aktualizacji / Revision Date / Datum der letzten Aktualisierung: 22.06.2021

LEGENDA / LEGEND / LEGENDE:

	Deklaracja zgodności Declaration of conformity EG-Konformitätserklärung		Klasa ochronności I Protection class I Schutzklasse I		Napięcie zasilania Power supply Speisespannung
	Źródło światła LED LED source LED Quelle		Technologia stałego strumienia świetlnego Constant luminous flux technology Konstante Lichtstromtechnologie		Dyrektywa RoHS The RoHS Directive RoHS Richtlinie
	Wymiary montażowe Mounting dimensions Montagemaße		Stopień szczelności IP IP protection marking Schutzklasse IP		Atest higieniczny PZH Hygiene certificate of the NIH Attest von Polnischer Hygieneanstalt
	Kod produktu Code Artikelnummer		Rodzaj klosza Cover Abdeckung		Moc oprawy Luminaire power Leistung der Leuchte
	Kąt rozsyłu światłości Light distribution angle Winkel der Lichtverteilung		Wymiary Dimensions Masse		Temperatura barwowa Color temperature Farbtemperatur
	Strumień świetlny Luminous flux Lichtstrom		Skuteczność świetlna Luminous efficiency Lichtausbeute der Leuchte		System sterowania DALI DALI control system Steuersystem DALI
	Kolor oprawy Luminaire color Leuchte Farbe		Waga Weight Gewicht		Nazwa produktu Product name Produktname
	Wskaźnik ośnienia przykrego Glare indicator Blendungsanzeige				